

51R24 FRONT/BACK LABEL INSPECTION

The 51R24 provides a two-sided label inspection and tamper resistant shrink band detection for beverages, sauces, and household goods. With a multi-camera inspection at speeds up to 700 containers per minute, this system accurately detects label and labeling errors to ensure your product best represents itself and your brand on the retail store shelf.

INSPECTIONS INCLUDE:

Label Folds and Tears

Spliced, Skewed, Wrong, or Missing Labels

Detection of Heat-Shrink Wrap Over Caps

Label Height and Other Application Defects



The world's most trusted brands trust us to help grow their business

WHY CHOOSE THE SILGAN VISION 51R24?

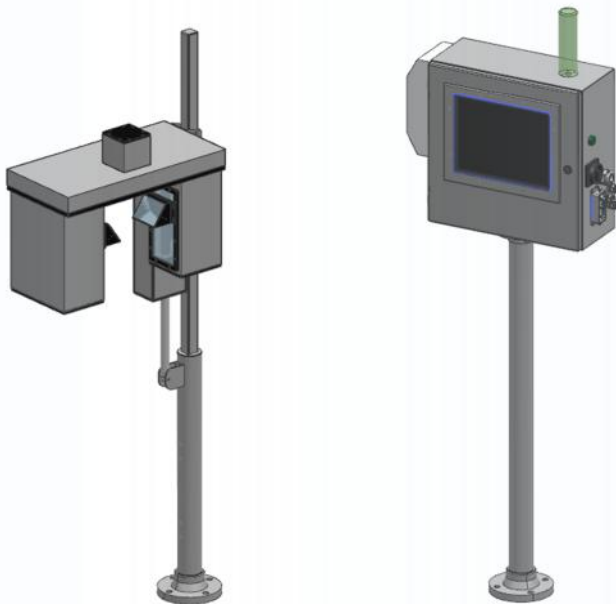

It Works: 100% product inspection prevents defects from going downstream

Efficient: System intelligence prevents poor product runs that result in costly spoilage

Easy to Use: User interface simplifies operation changeover and set up of new jobs

Durable: Stainless steel, NEMA4X design withstands food & beverage plant environments

Compact: Installs easily over existing conveyor and saves valuable floor space

No Hassle: Fully supported by the Silgan Vision Technical and Customer Service Teams

Want To Know More?



sales@silganequipment.com

WWW.SILGANEQUIPMENT.COM | 847.336.0552 | 1301 W. DUGDALE RD, WAUKEGAN, IL 60085

51R24 TECHNICAL SPECIFICATIONS

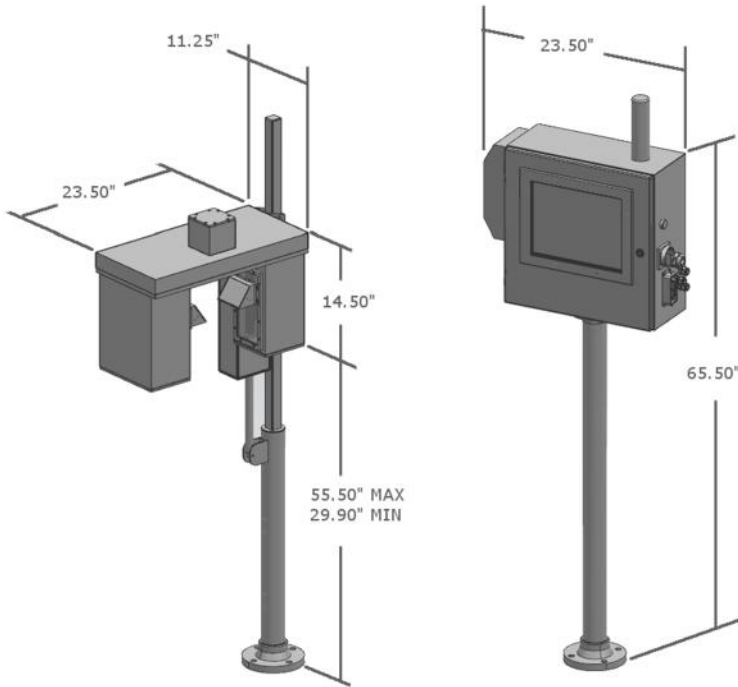

Model	51R24 Label Inspection
Camera Configuration	Multi-camera for Front and Back Two-Label Inspection
Interface	15" Touch Screen
Other Features	<ul style="list-style-type: none"> • Custom LED Lighting • Solid State Hard Drive with Backup • Motorized Tunnel Height Adjustment • Cabinet Cooler for Temperature Control • Ethernet Bay for Online Connectivity • Multi-Level Password Protect Feature • Teach Function for Auto Configuration • Saves up to 50 Recipes / Jobs • Status Billboard for Real-Time Data
NEMA Rating	4X - Watertight (Wash-Down Environment)
Electrical Requirements	120VAC 1 Phase
Environment Temp.	33° ~ 115°F
Space Required (x2)	Height: 65.5 Inches Width: 23.5 Inches Depth: 23.5 Inches

Choose From These Great Options:

Filler Capper Tracking System	Control Cabinet Cover
Tap Touch 600 Pneumatic Ejector (NEMA 4)	Spare Parts Kit
Soft Touch Diverter (NEMA 4X)	Paxton Cap Dryer
UPS & Surge Protector (NEMA 4X)	

Why Choose Silgan Vision?

- Silgan is a Vision pioneer and has served our customers for over 20 years with vision inspection solutions.
- Today, Silgan Vision business partners exceed their standards for quality and support world-wide. Many of the top food and beverage processors rely on us for their quality assurance programs.
- With our 24/7 support line and full-service technicians located throughout the continental US, we stand by our products and help you get the best out of your operation.
- Silgan Vision is a proud member of the Silgan family of companies. We deliver the best-in-class service you deserve. We know your packaging and can help you grow.

LET US HELP TAKE YOUR BUSINESS TO THE NEXT LEVEL!

Capping

Material Handling

Quality Inspection

Rebuild & Engineering Services



Take Advantage of Silgan's Large U.S. Service Network

Silgan Vision's 24hr Support Line: 877-205-3225