

51R56 CAP-ON-BOTTLE INSPECTION

The 51R56 is our latest model in a long line of closure inspection solutions. It is perfect for inspecting all beverage containers along with food and household products. At speeds up to 800 containers per minute, this system performs a 360-degree inspection for cap and application defects.

INSPECTIONS INCLUDE:

Cocked, Loose, Tight, Skewed, and Missing Caps

Tucked, Broken, and Missing Tamper Bands

Low Fill Levels

Cap Color and Other Inspections as Specified

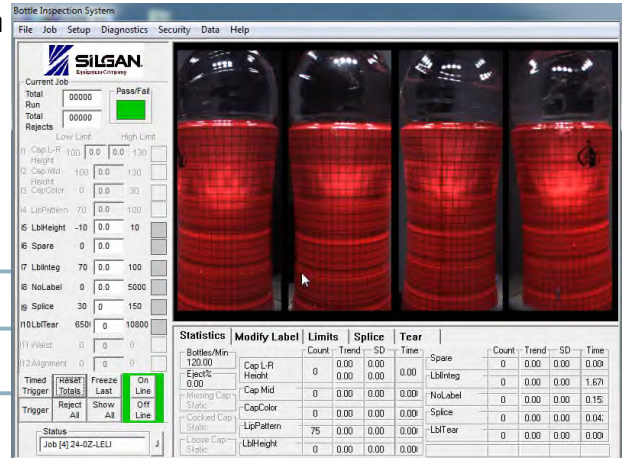

The world's most trusted brands trust Silgan to be their Partner for Innovation

WHY CHOOSE THE SILGAN 51R56?

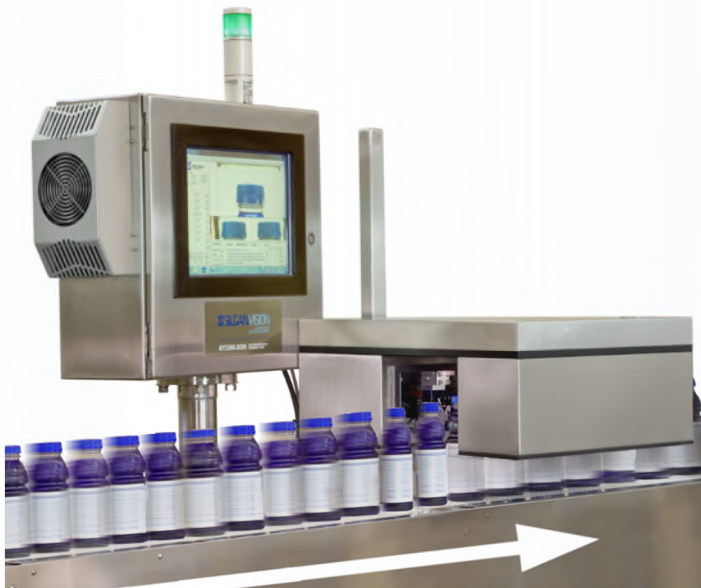

Simplicity: Installs easily over existing conveyor, saving valuable floor space. The user interface simplifies changeovers and new job setups.

Efficiency: 100% product inspection prevents defects from going downstream. The proprietary system intelligence prevents poor product runs that result in costly spoilage.

Reliability: The stainless steel, NEMA 4X design, withstands food and beverage plant environments. Our dedicated technical service team is there for all your inspection needs and our optional service agreement program makes it all hassle-free.

Want To Know More?



sales@silganequipment.com

51R56 TECHNICAL SPECIFICATIONS

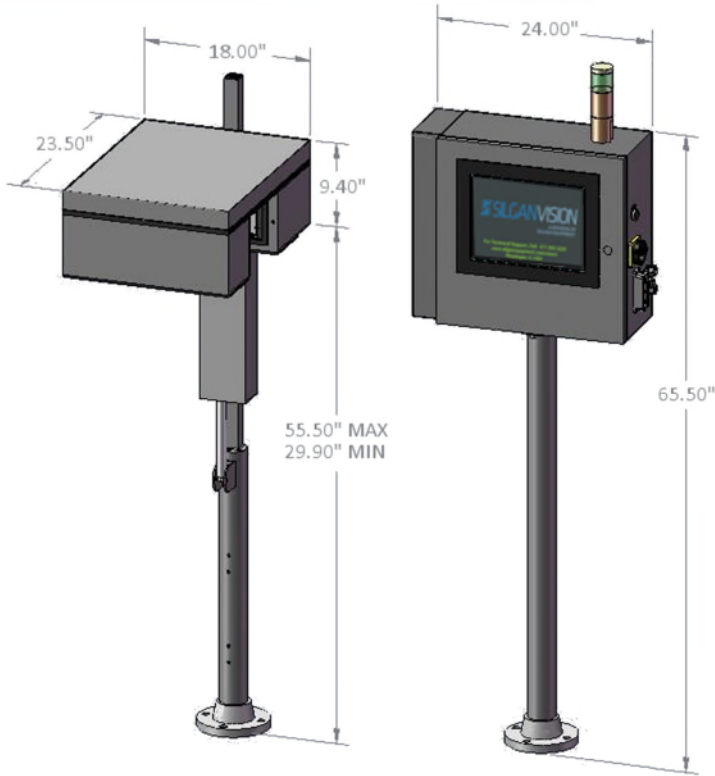

Model	51R56 Cap on Bottle Inspection
Cap Sizes	Ø28mm - Ø82mm
Camera Configuration	Multi-camera for 360° inspection
Interface	15" Touch Screen
Other Features	<ul style="list-style-type: none"> • Custom LED Lighting • Solid State Hard Drive with Backup • Motorized Tunnel Height Adjustment • Cabinet Cooler for Temperature Control • Ethernet Bay for Online Connectivity • Password Protect Feature • Teach Function for Auto Configuration • Saves up to 70 Recipes / Jobs • Status Billboard for Real-Time Data
NEMA Rating	4X - Watertight (Wash-Down Environment)
Electrical Requirements	120VAC 1 Phase
Environment Temp.	33° ~ 115°F
Space Required (x2)	Height: 65.5 Inches Width: 24 Inches Depth: 23.5 Inches

Choose From These Great Options:

Filler Capper Tracking System Tap Touch 600 Pneumatic Ejector (NEMA 4) Soft Touch Diverter (NEMA 4X) UPS & Surge Protector (NEMA 4X)	Control Cabinet Cover Spare Parts Kit Paxton Cap Dryer
---	--

Why Choose Silgan Equipment?

- Silgan's expertise and leadership has served our customers for over 20 years with inspection solutions.
- Today, Silgan Equipment business partners exceed their standards for quality and support world-wide. Many of the top food and beverage processors rely on us for their quality assurance programs.
- With our 24/7 support line and full-service technicians located throughout the continental US, we stand by our products and help you get the best out of your operation.
- Silgan Equipment is a proud member of the Silgan family of companies. We deliver the best-in-class service you deserve. We know your packaging and can help you grow.

LET US HELP TAKE YOUR BUSINESS TO THE NEXT LEVEL!

Capping

Material Handling

★ Quality Inspection

Rebuild & Engineering Services



Take Advantage of Silgan's Large U.S. Service Network

To start improving your productivity, call: 847.336.0552