

## AIR TOUCH 600 DIVERTER

The Air Touch 600 is designed with your quality efforts in mind, offering a safe and reliable way to divert bottles and jars, and cups minimizing product loss, damage to packaging, and messy cleanup. Whether you're removing defects, sampling quality, or diverting product-stream, the Air Touch 600 helps keep production on-track.

### FEATURES:

[Air Nozzle For Gently Diverting Product](#)

[Adjustable Nozzle Position & Force Output](#)

[Stainless Steel Construction For Enhanced Durability](#)

[Direct Mounting For Quick Installation Into Production](#)



The world's most trusted brands trust Silgan to be their Partner for Innovation

## WHY CHOOSE THE SILGAN AIR TOUCH 600?



**Simplicity:** Installs easily over existing conveyor, saving valuable floor space. The user interface simplifies changeovers and new job setups.

**Efficiency:** 100% product inspection prevents defects from going downstream. The proprietary system intelligence prevents poor product runs that result in costly spoilage.

**Reliability:** The stainless steel, NEMA 4X design, withstands food and beverage plant environments. Our dedicated technical service team is there for all your inspection needs and our optional service agreement program makes it all hassle-free.

Want To Know More?



[sales@silganequipment.com](mailto:sales@silganequipment.com)

# AIR TOUCH 600 TECHNICAL SPECIFICATIONS

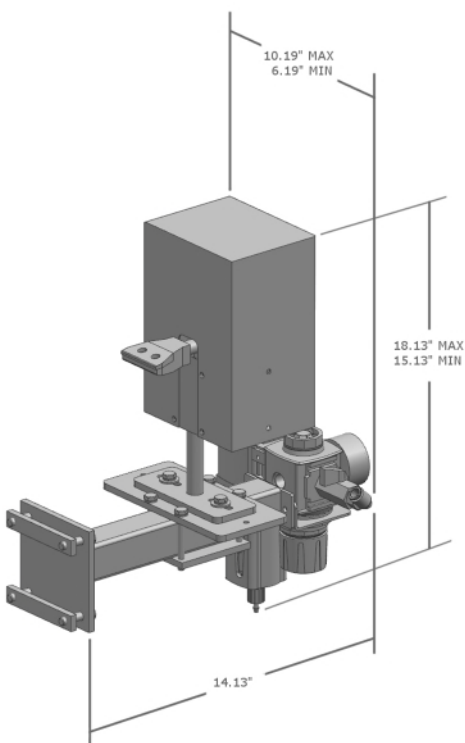

<b>Model</b>	Air Touch 600
<b>How It Works</b>	<ol style="list-style-type: none"> <li>1. Signal Received From Sensor or Up-stream Operation</li> <li>2. Product is Tracked on Variable Speed Conveyor</li> <li>3. Diversion Profile is Calculated on Conveyor and Product Data</li> <li>4. Product is Diverted</li> </ol>
<b>Speed</b>	600 Containers Per Minute
<b>Container Weight</b>	Up to 0.5 lb. Total Weight
<b>Compatibility</b>	Accepts Most Standard 24 VDC Divert Signals
<b>Air Requirements</b>	100 PSI, 35 SCFM Depends on Application
<b>NEMA Rating</b>	4 - Watertight (Wash-Down Environment)
<b>Electrical Requirements</b>	Control Voltage 24VDC
<b>Environment Temp.</b>	50° ~ 100°F
<b>Space Required</b>	Height : 18.13 Inches Width : 10.19 Inches Depth : 14.13 Inches

## Silgan Equipment: Helping You Get The Best Out Of Your Line

### Why Choose Silgan Equipment?

- Silgan's expertise and leadership has served our customers for over 20 years with inspection solutions.
- Today, Silgan Equipment business partners exceed their standards for quality and support world-wide. Many of the top food and beverage processors rely on us for their quality assurance programs.
- With our 24/7 support line and full-service technicians located throughout the continental US, we stand by our products and help you get the best out of your operation.
- Silgan Equipment is a proud member of the Silgan family of companies. We deliver the best-in-class service you deserve. We know your packaging and can help you grow.

*LET US HELP TAKE YOUR BUSINESS TO THE NEXT LEVEL!*

**Capping**

**Material Handling**

★ **Quality Inspection**

**Rebuild & Engineering Services**



Take Advantage of Silgan's Large U.S. Service Network

To start improving your productivity, call: 847.336.0552